

Data Sheet SFA30

Formaldehyde Sensor Module for HVAC and Indoor Air Quality Applications

Target applications

- Real-time reading of HCHO gas concentration in parts per billion
- Air Conditioners and Air Exchangers
- Air Purifiers
- Indoor Air Quality Monitors



Key features

- Low cross-sensitivity to ethanol
- Long-term stability and 6 years' service life time
- Patented electrochemical cell with anti-dry technology
- I²C/UART interface with lifetime-calibrated output
- Fully temperature and humidity compensated via Sensirion RHT sensor

SFA30 is a formaldehyde detection module based on electrochemical sensing technology optimized for lowest false alarm rates. The SFA30 HCHO sensor has a low cross-sensitivity to ethanol and is optimized to operate in the low parts-per-billion (ppb) range to accurately detect low HCHO concentrations around the WHO reference value for indoor exposure.

Temperature and humidity compensation via an integrated Sensirion RHT sensor and an integrated microprocessor ensures reliable performance in changing indoor environments. The sensor can withstand adverse environmental conditions during storage, handling and transportation.

The robust sensor has a lifetime of 6 years due to its advanced anti-dry technology. Each SFA30 is factory-calibrated and can be easily integrated via I²C or UART interface into your device. The low power consumption allows for battery operation. This makes SFA30 a reliable, easy-to-use and high quality HCHO&RHT combo sensing solution.

Content

1 Sensor Performance	3
2 Specifications	4
3 Sensor Output Signal Description	6
4 Operation and Communication through the UART Interface	7
5 Mechanical Specifications	13
6 Ordering Information	14
7 Packaging Information	14
8 Important Notices	15
Headquarters and Subsidiaries	15
9 Revision History	16

1 Sensor Performance

1.1 Formaldehyde Sensing Specifications

Default conditions of 25 °C and 3.3 V supply voltage apply to values in the table below, unless otherwise stated.

Parameter	Conditions	Min	Typical	Max	Units
Standard formaldehyde measurement range	-	0 ... 1000			ppb
Output limit	Value at which the output saturates	5000			ppb
Resolution	-			1	ppb
Accuracy	(50 ± 5) %RH, (25 ± 3) °C; Formaldehyde concentration 0 ... 200 ppb in otherwise clean air		±20 ppb or ±20% of measured value, whichever is larger		-
Repeatability			±5 ppb or ±5% of measured value, whichever is larger		-
Cross sensitivity to ethanol	Tested at 5.0 ppm ethanol		<0.5% (<25 ppb)		-
Standard operating temperature		0		40	°C
Standard operating humidity	Non-condensing	10		90	% RH
Response time	Response to concentration change		<2		min
Service life	At standard conditions		>6		years
Long-term drift	At standard conditions		<5 ppb or <5% of measured value, whichever is larger		per year

Table 1: Formaldehyde sensor specifications

1.2 Humidity Sensing Specifications¹

Parameter	Conditions	Min	Typical	Max	Units
Humidity measurement range	-	0 ... 100			% RH
Accuracy	10 ... 40 °C, 10 ... 90 % RH		± 2.5	± 5	% RH
Repeatability			± 0.1		% RH
Long-term drift			< 0.25	< 0.5	% RH / y

Table 2: Humidity sensor specifications

1.3 Temperature Sensing Specifications¹

Parameter	Conditions	Min	Typical	Max	Units
Temperature measurement range	-	-20 ... 50			°C
Accuracy	0 ... 50 °C		± 0.2	± 0.5	°C
Repeatability			± 0.1		°C
Long-term drift			< 0.02	< 0.04	°C / y

Table 3: Temperature sensor specifications

¹ The design-in of the SFA30 in the final application and environment affect the accuracy of the RH and T sensor. Effects from heat sources and heat sinks have to be considered.

2 Specifications

2.1 Electrical Specifications

Parameter	Symbol	Conditions	Min.	Typical	Max.	Units	Comments
Supply voltage DC	V _{DD}		3.15	3.3 or 5.0	5.5	V	
Supply current	I _{DD}	Measurement - average		1.0	2.0	mA	
		Measurement - peak		2.5	5.0	mA	
		Idle mode		0.5	1.0	mA	
Input high level voltage	V _{IH}		1.75		5.5	V	
Input low level voltage	V _{IL}		-0.3		0.9	V	
Output high level voltage	V _{OH}	Max. current on I/O	2.4			V	
Output low level voltage	V _{OL}	pin 6 mA			0.4	V	

Table 4: Electrical characteristics

2.2 Timing Specifications

Parameter	Symbol	Min.	Typical	Max.	Units	Comments
I ² C SCL frequency	f _{I2C}			100	kHz	
UART baud rate	f _{UART}		115'200		baud	
Update rate		1.8	2	2.2	Hz	
Recommended read out interval		0.5	1	60	sec	See section 3.1 for details

Table 5: Timing specifications

2.3 Absolute Minimum and Maximum Ratings

Stress levels beyond those listed in Table 6 may cause permanent damage to the device. These are stress ratings only and functional operation of the device at these conditions cannot be guaranteed. Exposure to the absolute maximum rating conditions for extended periods may affect the reliability of the device. Ratings are only tested each at a time.

Parameter	Rating	Unit
Operating temperature	0 ... +50	°C
Minimum operating humidity	10	% RH
Maximum operating humidity	95 % RH or 40°C dew point, whichever is lower. Non-condensing	-
Short term storage temperature ²	-20 ... +70	°C
Short term storage humidity ²	10 ... 95, non-condensing	% RH
Recommended storage temperature ³	10 ... 30	°C
Recommended storage humidity ³	30 ... 70	% RH
Supply voltage V _{DD}	-0.3 ... +6.0	V
I/O pins when configured as input (SEL, RX/SDA, SCL)	-0.3 ... +6.0	V
Max. current on I/O pin when configured as output (TX)	15	mA

Table 6: Absolute minimum and maximum ratings

² Short term storage refers to temporary conditions during e.g. transport.

³ Recommended optimum storage conditions.

2.4 Electrostatic Discharge



Warning: The sensor module is susceptible to ESD damages, especially when touching the exposed electronics. During handling and testing, suitable ESD precautions must be taken.

Parameter	Rating	Unit
Electrostatic discharge voltage (human body model)	Class 1C (1000 V)	
Electrostatic discharge voltage (charge device model)	Class C2a (500 V)	

Table 7: ESD protection ratings

2.5 Pin Assignment

The interface connector (Molex Micro-Lock Plus, 1.25 mm pitch, 7 circuits, Molex part number 5055670771) is located at the short edge of the sensor PCB. The mating connector is Molex part number 5055650701. In Figure 1 a description of the pin assignment is given.

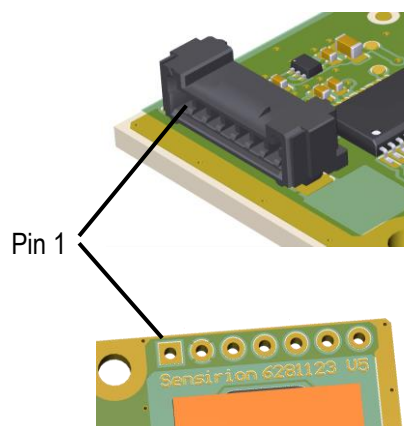

Figure 1: Pin layout of Molex Micro-Lock Plus connector and 0.1" pitch contact pads

Pin	Name	Description
1	VDD	Supply voltage
2	GND	Ground
3	RX	UART: Receiving pin for communication
	SDA	I ² C: Serial data input / output
4	TX	UART: Transmitting pin for communication
	SCL	I ² C: Serial clock input
5	SEL	Interface select: - Leave floating or pull to VDD to select UART - Pull to GND to select I ² C
6	NC	Do not connect
7	NC	Do not connect

Table 8: SFA31 pin assignment

The Sensirion formaldehyde sensor module SFA30 offers both a UART⁴ and an I²C interface. For connection cables longer than 20 cm, Sensirion recommends using the UART interface due to its higher robustness against electromagnetic interference.

See section 4 for the description of the UART interface. The description of the I²C interface is available on request.

⁴ Universal Asynchronous Receiver Transmitter.

3 Sensor Output Signal Description

3.1 Flexible Readout Interval

Different applications and situations require different data rates. In some situations, a frequent readout is desired, in other situations this only generates an excess amount of data to be processed. Therefore, the SFA30 sensor offers a flexible readout interval with an optimal signal-to-noise ratio in any case.

After the sensor receives the “start continuous measurement” command it enters the continuous measurement mode and continuously performs measurements of ~0.5 sec duration. Therefore, the formaldehyde concentration, humidity, and temperature values are updated every 0.5 sec (see Table 5).

The output value for each signal corresponds to the average \bar{x} of all individual 0.5 sec measurements x_i since the last readout. This has the benefit that the user can read out the sensor at the desired speed. During the first 60 seconds of averaging, the averaged value is obtained as the arithmetic mean.

$$\bar{x} = \sum_{i=1}^N \frac{x_i}{N} \quad \text{for } t < 60 \text{ sec}$$

When the reading interval is slower than 60 sec, the sensor will continue to average, but with a different algorithm. In this algorithm exponential smoothing is used, with a smoothing factor $\alpha = 0.0167$.

$$S_k = \alpha \cdot x_i + (1 - \alpha) \cdot S_{k-1}, \quad S_0 = \bar{x}, \quad \text{for } t > 60 \text{ sec}$$

Where S_0 is the arithmetic mean value after the first 60 seconds and the output value corresponds to the last available S_k .

With an exponential smoothing factor of $\alpha = 0.0167$, the filtered output corresponds approximately to an average value of the last 60 seconds before reading. Please refer to relevant literature for more information about exponential smoothing.

In the first 0.5 seconds after a measurement has been started with the “start continuous measurement” command, no measurement result is available and the sensor returns no data.

If a read command is issued too short after the last read, i.e. before a new 0.5 sec measurement is available, the sensor returns the latest available measurement data again.

3.2 Temperature and Humidity Measurement

The SFA30 module’s on-board SHT humidity and temperature sensor provides reliable temperature and humidity readings. The SFA30 module only uses a small amount of power and hence produces very limited self-heating. Therefore, the temperature reading is an accurate measure for the local temperature at the installation position of the SFA30 module. Depending on the integration of the SFA30 module into the user’s device, the temperature reading of the SHT sensor can be influenced by nearby heat sources and therefore be different from the actual ambient temperature outside the device.

Also the response time of the temperature sensor depends on the details of the integration, like air circulation, etc.

3.3 Power-up

After power-up, the sensor’s electronics need to boot and equilibrate first. Therefore, the sensor’s formaldehyde output is suppressed for the first 10 seconds after power-up. If a measurement is started and read out during this power-up time, the sensor returns zero for the formaldehyde output until the initial 10 seconds after power-up have elapsed. The humidity and temperature outputs are available immediately after power-up.

Example: If a measurement is started 3 seconds after power-up, the sensor’s formaldehyde output will be zero during the first 7 seconds after the start of the measurement.

4 Operation and Communication through the UART Interface

The following UART settings have to be used:

- Baud Rate: 115'200 bit/s
- Data Bits: 8
- Parity: None
- Stop Bit: 1

4.1 Physical Layer

The SFA30 sensor has separate RX and TX lines with unipolar logic levels. A transmitted byte looks as in Figure 2.



Figure 2: Transmitted byte

4.2 SHDLIC Frame Layer

On top of the UART physical layer, the Sensirion Formaldehyde Sensor Module uses the very powerful and easy-to-implement Sensirion High-Level Data Link Control (SHDLIC) protocol. It is a serial communication protocol based on a master/slave architecture. The SFA30 acts as the slave device.

Data is transferred in logical units called frames. Every transfer is initiated by the master sending a Master-Out-Slave-In (MOSI, frame direction from master to slave) frame. The slave will respond to the MOSI frame with a slave response, or Master-In-Slave-Out (MISO, frame direction from slave to master) frame.

The two types of frames are shown in Figure 3.

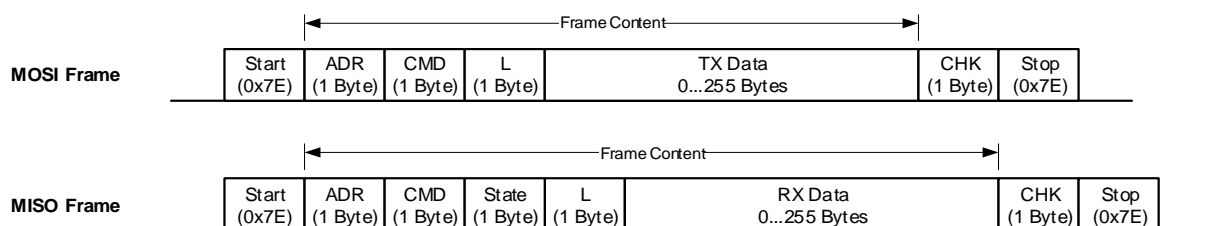

Figure 3: MOSI and MISO frames structure

Start/Stop Byte and Byte-Stuffing

The 0x7E character is sent at the beginning and at the end of the frame to signal frame start and stop. If this byte 0x7E occurs anywhere else in the frame, it must be replaced by two other bytes (byte-stuffing). This also applies to the characters 0x7D, 0x11 and 0x13. Use Table 9 for byte-stuffing.

Original data byte	Transferred data bytes
0x7E	0x7D, 0x5E
0x7D	0x7D, 0x5D
0x11	0x7D, 0x31
0x13	0x7D, 0x33

Table 9: Reference table for byte-stuffing

Example: Data to send = [0x43, 0x11, 0x7F] → Data transmitted = [0x43, 0x7D, 0x31, 0x7F].

Address

The slave device address is always 0.

Command

In the MOSI frame the command tells the device what to do with the transmitted data. In the MISO frame, the slave returns the received command.

Length

Length of the “TX Data” or “RX Data” field (before byte-stuffing).

Data

The data has a usable size of [0...255] bytes (original data, before byte-stuffing). The meaning of the data content depends on the command.

Checksum

The checksum is built before byte-stuffing and checked after removing stuffed bytes from the frame. The checksum is defined as follows:

1. Sum all bytes between start and stop (without start and stop bytes).
2. Take the LSB of the result and invert it. This will be the checksum.

For a MOSI frame use Address, Command, Length and Data to calculate the checksum.

For a MISO frame use Address, Command, State, Length and Data to calculate the checksum.

Example:

Addr.	CMD	L	Tx Data 2 Bytes	CHK
0x00	0x00	0x02	0x01, 0x01	0xFB

Figure 4: MOSI frame without start/stop and without byte stuffing

The checksum is calculated in this example as follows:

Address	0x00
CMD	0x00
L	0x02
Data 0	0x01
Data 1	0x01
Sum	0x04
LSB of Sum	0x04
Inverted (=Checksum)	0xFB

Table 10: Reference table for error codes

State

The MISO frame contains a state byte, which allows the master to detect communication and execution errors. The first bit indicates a general device error, which was not necessarily caused by the execution of the command. Figure 5 shows the composition of the state byte.

b7	b6					b0
Error-Flag	Execution Error Code					

Figure 5: State byte structure

If the Error-Flag is set, the cause of the error can be queried via the Device Status Register.

The Execution Error Code signals all errors which occur while processing the frame or executing the command. The following table shows the error codes which can be reported from the device. Note that some of these errors are system internal errors which require additional knowledge to be understood. In case of a problem, they will help Sensirion to localize and solve the issue.

Error Code		Meaning
dec	hex	
0	0x00	No error
1	0x01	Wrong data length for this command (too much or too little data)
2	0x02	Unknown command
3	0x03	No access right for command
4	0x04	Illegal command parameter or parameter out of allowed range
32	0x20	No measurement data available
67	0x43	Command not allowed in current state
68	0x44	(Internal error)
127	0x7F	General error

Table 11: Reference table for error codes

4.3 UART / SHDLIC Commands for the SFA30

The following table shows an overview of the available SHDLIC commands.

CMD	Command	Read / Write / Execute
0x00	Start Measurement	Execute
0x01	Stop Measurement	Execute
0x03	Read Measured Values	Read
0xD0	Read Device Information	Read
0xD3	Reset	Execute

Table 12: Reference table for SHDLIC commands

4.3.1 Start Measurement (CMD: 0x00)

Starts the continuous measurement.

After power-up, the sensor module is in idle-mode. Before any measurement values can be read, the measurement-mode needs to be started using this command.

Available:

Only in idle mode, i.e. when no measurement is running. If a measurement is already running, stop it first with command 0x01.

MOSI Data:

Byte #	Datatype	Description
0	uint8	Subcommand, this value must be set to 0x00

MISO Data: No data.

Example Frames:

MOSI	0x7E 0x00 0x00 0x01 0x00 0xFE 0x7E
MISO	0x7E 0x00 0x00 0x00 0x00 0xFF 0x7E

4.3.2 Stop Measurement (CMD: 0x01)

Stops the measurement. Use this command to return to the initial state (idle-mode).

Available:

Only in measurement mode. Returns error 67 (hex 0x43) if no measurement is running.

MOSI Data: No data.

MISO Data: No data.

Example Frames:

MOSI	0x7E 0x00 0x01 0x00 0xFE 0x7E
MISO	0x7E 0x00 0x01 0x00 0x00 0xFE 0x7E

4.3.3 Read Measured Values (CMD: 0x03)

Reads the measured values from the module.

The sensor will always return the latest available measurement. If a read measured value command is issued before a new measurement is available, the last available measurement will be sent again in the reply. See section 3.1 for further details. Before the first sensor reading is available after starting the continuous measurement, the sensor returns an empty frame and error code 32 (hex 0x20).

Available:

Always. Will return no data if no measurement is running.

MOSI Data:

Byte #	Datatype	Description
0	uint8 unsigned 8-bit integer	Subcommand, this value must be set to 0x02

MISO Data:

Byte #	Datatype	Description	Scale Factor
0..1	int16 signed 16-bit integer	Formaldehyde Concentration [ppb]	5 (ppb) ⁻¹
2..3	int16 signed 16-bit integer	Measured Relative Humidity [%RH]	100 (%RH) ⁻¹
4..5	int16 signed 16-bit integer	Measured Temperature [°C]	200 (°C) ⁻¹

To convert the sensor's integer output to physical values, divide by the corresponding scale factor.

The data format for all signals is signed i16 integer with negative values (only relevant for temperature) in the two's complement representation.

Example Frames:

MOSI	0x7E 0x00 0x03 0x01 0x02 0xF9 0x7E
MISO	Response frame with measurement values: 0x7E 0x00 0x03 0x00 0x06 0x00 0x63 0x10 0x9A 0x7D 0x31 0xBE 0x1A 0x7E

Note that in this example the return frame contains a stuffed byte (0x7D, 0x31)→0x11.

The values read in this example frame are:

- (0x00, 0x63) Formaldehyde concentration in ppb: $(256 \cdot 0 + 99) / 5 \text{ (ppb)}^{-1} = 19.8 \text{ ppb}$
- (0x10, 0x9A) Relative humidity in % RH: $(256 \cdot 16 + 154) / 100 \text{ (%RH)}^{-1} = 42.5 \text{ %RH}$
- (0x11, 0xBE) Temperature in °C: $(256 \cdot 17 + 190) / 200 \text{ (°C)}^{-1} = 22.71 \text{ °C}$

4.3.4 Get Device Information (CMD: 0xD0)

Read information such as the device marking.

Available: Always.

MOSI Data:

Byte #	Datatype	Description
0	uint8	Subcommand, this value must be set to 0x06 to read the device marking

MISO Data:

Subcommand 0x06: Device marking (same as barcode on sensor module) as ASCII formatted C-string including terminating Null character. Max. 32 bytes.

Example Frames:

MOSI	0x7E 0x00 0xD0 0x01 0x06 0x28 0x7E
MISO	0x7E 0x00 0xD0 0x00 0x7d 0x31 0x32 0x30 0x33 0x36 0x35 0x43 0x36 0x32 0x39 0x46 0x30 0x37 0x33 0x42 0x45 0x31 0x00 0xA2 0x7E

Note that in this example the return frame contains a stuffed byte (0x7D, 0x31)→0x11.

In this example, the device marking reads "20365C629F073BE1".

4.3.5 Device Reset (CMD: 0xD3)

Soft reset command. After calling this command, the module is in the same state as after a Power-Reset. The reset is executed after sending the MISO response frame.

Available: Always.

MOSI Data: No data.

MISO Data: No data.

Example Frames:

MOSI	0x7E 0x00 0xD3 0x00 0x2C 0x7E
MISO	0x7E 0x00 0xD3 0x00 0x00 0x2C 0x7E

5 Mechanical Specifications

5.1 Handling



Warning: The SFA30 sensor module is susceptible to mechanical damages. During handling, testing, and assembly the part should be handled with care. In particular, exerting force or pressure on the electrochemical sensor from the top (orange-brown) or bottom (black) must be avoided. See the SFA30 handling instructions for further details.

5.2 Product Drawing

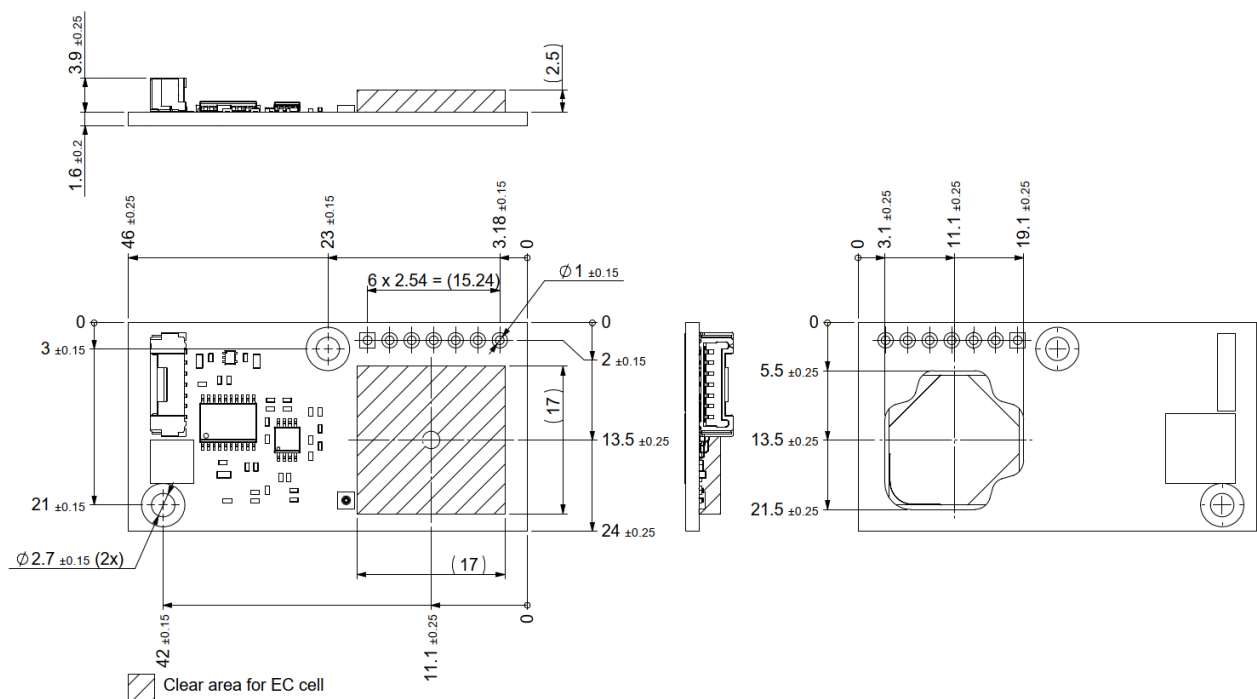

Figure 6: Dimensions of the SFA30 Sensirion formaldehyde sensor module. All dimensions in mm. Areas marked as “Clear area for EC cell” must not be obstructed by design-in.

6 Ordering Information

Product	Manufacturer part number	Article Number
SFA30-D-T HCHO Sensor Module	SFA30-D-T	3.000.422
SEK-SFA30 Evaluation Kit	SEK-SFA30	3.000.463

Table 13: Ordering information

The SEK-SFA30 Evaluation Kit contains:

- the SFA30 Sensor Module,
- an USB-UART interface cable for easy connection to a computer
- a jumper wire cable set for easy connection to 2.54 mm pitch connectors on embedded prototyping platforms

The SEK-SFA30 Evaluation Kit is designed for use with Sensirion’s Control Center evaluation kit software or with embedded prototyping platforms.

7 Packaging Information

The SFA30-D-T formaldehyde sensor module is shipped in trays of 40 pcs each.

The tray dimension is (360 x 254 x 14.5) mm³. For stacked trays, the height per tray can be considered as 8 mm. A stack of 11 trays (10 full trays + 1 cover) has a total height of approx. 95 mm.

For production parts, 10 full trays + 1 cover (400 sensors) will be packaged in one ESD bag. Two ESD bags (800 sensors) fill one box.

8 Important Notices

Warning, Personal Injury

Do not use this product as safety or emergency stop devices or in any other application where failure of the product could result in personal injury. Do not use this product for applications other than its intended and authorized use. Before installing, handling, using or servicing this product, please consult the data sheet and application notes. Failure to comply with these instructions could result in death or serious injury.

If the Buyer shall purchase or use SENSIRION products for any unintended or unauthorized application, Buyer shall defend, indemnify and hold harmless SENSIRION and its officers, employees, subsidiaries, affiliates and distributors against all claims, costs, damages and expenses, and reasonable attorney fees arising out of, directly or indirectly, any claim of personal injury or death associated with such unintended or unauthorized use, even if SENSIRION shall be allegedly negligent with respect to the design or the manufacture of the product.

ESD Precautions

The inherent design of this component causes it to be sensitive to electrostatic discharge (ESD). To prevent ESD-induced damage and/or degradation, take customary and statutory ESD precautions when handling this product.

See application note "ESD, Latchup and EMC" for more information.

Warranty

SENSIRION warrants solely to the original purchaser of this product for a period of 12 months (one year) from the date of delivery that this product shall be of the quality, material and workmanship defined in SENSIRION's published specifications of the product. Within such period, if proven to be defective, SENSIRION shall repair and/or replace this product, in SENSIRION's discretion, free of charge to the Buyer, provided that:

- notice in writing describing the defects shall be given to SENSIRION within fourteen (14) days after their appearance;
- such defects shall be found, to SENSIRION's reasonable satisfaction, to have arisen from SENSIRION's faulty design, material, or workmanship;
- the defective product shall be returned to SENSIRION's factory at the Buyer's expense; and
- the warranty period for any repaired or replaced product shall be limited to the unexpired portion of the original period.

This warranty does not apply to any equipment which has not been installed and used within the specifications recommended by SENSIRION for the intended and proper use of the equipment. EXCEPT FOR THE WARRANTIES EXPRESSLY SET FORTH HEREIN, SENSIRION MAKES NO WARRANTIES, EITHER EXPRESS OR IMPLIED, WITH RESPECT TO THE PRODUCT. ANY AND ALL WARRANTIES, INCLUDING WITHOUT LIMITATION, WARRANTIES OF MERCHANTABILITY OR FITNESS FOR A PARTICULAR PURPOSE, ARE EXPRESSLY EXCLUDED AND DECLINED.

SENSIRION is only liable for defects of this product arising under the conditions of operation provided for in the data sheet and proper use of the goods. SENSIRION explicitly disclaims all warranties, express or implied, for any period during which the goods are operated or stored not in accordance with the technical specifications.

SENSIRION does not assume any liability arising out of any application or use of any product or circuit and specifically disclaims any and all liability, including without limitation consequential or incidental damages. All operating parameters, including without limitation recommended parameters, must be validated for each customer's applications by customer's technical experts. Recommended parameters can and do vary in different applications.

SENSIRION reserves the right, without further notice, (i) to change the product specifications and/or the information in this document and (ii) to improve reliability, functions and design of this product.

Copyright © 2020, by SENSIRION. CMOSens® is a trademark of Sensirion. All rights reserved

Headquarters and Subsidiaries

Sensirion AG

Laubisruestr. 50
CH-8712 Staefa ZH
Switzerland

phone: +41 44 306 40 00
fax: +41 44 306 40 30
info@sensirion.com
www.sensirion.com

Sensirion Taiwan Co. Ltd

phone: +886 3 5506701
info@sensirion.com
www.sensirion.com

Sensirion Inc., USA

phone: +1 312 690 5858
info-us@sensirion.com
www.sensirion.com

Sensirion Japan Co. Ltd.

phone: +81 3 3444 4940
info-jp@sensirion.com
www.sensirion.co.jp

Sensirion Korea Co. Ltd.

phone: +82 31 337 7700~3
info-kr@sensirion.com
www.sensirion.co.kr

Sensirion China Co. Ltd.

phone: +86 755 8252 1501
info-cn@sensirion.com
www.sensirion.com.cn

To find your local representative, please visit www.sensirion.com/distributors

9 Revision History

Date	Revision	Changes
October 2020	1.0	Initial Release
November 2020	1.1	Changed to D1
December 2022	1.2	Added pin assignment (section 2.5)